

Rolled steels for general structure

1 Scope This Standard specifies the hot rolled steels used for general structure such as bridges, ships, rolling stocks and other structures (hereafter referred to as "steel product").

2 Normative references The standards listed in attached table 1 contain provisions which, through reference in this Standard, constitute provisions of this Standard. The most recent editions of the standards (including amendments) shall be applied.

3 Grade and symbol The steel product shall be classified into four categories and their symbols shall be as given in table 1.

Table 1 Symbol of grade

| Symbol of grade | Applicable steel product |
|-----------------|--|
| SS330 | Steel plates and sheets, steel strip in coil, flats and bars |
| SS400 | Steel plates and sheets, steel strip in coil, sections, flats and bars |
| SS490 | |
| SS540 | Steel plates and sheets, steel strip in coil, sections and flats 40 mm or under in thickness and steel bars 40 mm or under in diameter, side length or distance across flats |

Remarks : Steel bars include bar-in-coils.

4 Chemical composition The steel product shall be tested in accordance with 8.1 and the cast analysis values thereof shall be as given in table 2.

Table 2 Chemical composition

Unit: %

| Symbol of grade | C | Mn | P | S |
|-----------------|-----------|-----------|------------|------------|
| SS330 | — | — | 0.050 max. | 0.050 max. |
| SS400 | — | — | 0.050 max. | 0.050 max. |
| SS490 | | | | |
| SS540 | 0.30 max. | 1.60 max. | 0.040 max. | 0.040 max. |

Remarks : Alloying elements other than those given in table 2 may be added as necessary.

5 Mechanical properties The steel product shall be tested in accordance with 8.2 and the yield point or yield strength, tensile strength, elongation and bendability thereof shall be as given in table 3.

As to the bendability, the outside surface of the bent portion shall be free from visible crack.



Table 3 Mechanical properties

| Symbol of grade | Yield point or yield strength N/mm ² | | | | Tensile strength N/mm ² | Thickness of steel product ⁽¹⁾ mm | Test piece | Elongation % | Bendability | | |
|-----------------|--|----------------------------|-----------------------------|----------|---|--|------------|---------------------|------------------|---|------------|
| | Thickness of steel product ⁽¹⁾ mm | | | | | | | | Angle of bending | Inside radius | Test piece |
| | 16 or under | Over 16 up to and incl. 40 | Over 40 up to and incl. 100 | Over 100 | | | | | | | |
| SS330 | 205 min. | 195 min. | 175 min. | 165 min. | 330 to 430 | Steel plates and sheets, steel strip in coil and flats 5 or under in thickness | No. 5 | 26 min. | 180° | Half of the thickness | No. 1 |
| | | | | | | Steel plates and sheets, steel strip in coil and flats over 5 up to and incl. 16 in thickness | No. 1A | 21 min. | | | |
| | | | | | | Steel plates and sheets, steel strip in coil and flats over 16 up to and incl. 50 in thickness | No. 1A | 26 min. | | | |
| | | | | | | Steel plates and sheets, and flats over 40 in thickness | No. 4 | 28 min. | | | |
| | | | | | | Steel bars 25 or under in diameter, side or distance across flats | No. 2 | 25 min. | 180° | Half of the diameter, side or distance across flats | |
| | | | | | | Steel bars over 25 in diameter, side or distance across flats | No. 14A | 28 min. | | | |

Table 3 (continued)

| Symbol of grade | Yield point or yield strength N/mm ² | | | | Tensile strength N/mm ² | Thickness of steel product ⁽¹⁾ mm | Test piece | Elongation % | Bendability | | |
|-----------------|--|----------------------------|-----------------------------|----------|---|--|------------|---------------------|------------------|---|------------|
| | Thickness of steel product ⁽¹⁾ mm | | | | | | | | Angle of bending | Inside radius | Test piece |
| | 16 or under | Over 16 up to and incl. 40 | Over 40 up to and incl. 100 | Over 100 | | | | | | | |
| SS400 | 245 min. | 235 min. | 215 min. | 205 min. | 400 to 510 | Steel plates and sheets, steel strip in coil, flats and sections 5 or under in thickness | No. 5 | 21 min. | 180° | 1.5 times the thickness | No. 1 |
| | | | | | | Steel plates and sheets, steel strip in coil, flats and sections over 5 up to and incl. 16 in thickness | No. 1A | 17 min. | | | |
| | | | | | | Steel plates and sheets, steel strip in coil, flats and sections over 16 up to and incl. 50 in thickness | No. 1A | 21 min. | | | |
| | | | | | | Steel plates and sheets, flats and sections over 40 in thickness | No. 4 | 23 min. | | | |
| | | | | | | Steel bars 25 or under in diameter, side or distance across flats | No. 2 | 20 min. | 180° | 1.5 times the diameter, side or distance across flats | No. 2 |
| | | | | | | Steel bars over 25 in diameter, side or distance across flats | No. 14A | 22 min. | | | |

Table 3 (continued)

| Symbol of grade | Yield point or yield strength N/mm ² | | | | Tensile strength N/mm ² | Thickness of steel product ⁽¹⁾ mm | Test piece | Elongation % | Bendability | | |
|-----------------|--|----------------------------|-----------------------------|----------|---|--|------------|---------------------|------------------|---|------------|
| | Thickness of steel product ⁽¹⁾ mm | | | | | | | | Angle of bending | Inside radius | Test piece |
| | 16 or under | Over 16 up to and incl. 40 | Over 40 up to and incl. 100 | Over 100 | | | | | | | |
| SS490 | 285 min. | 275 min. | 255 min. | 245 min. | 490 to 610 | Steel plates and sheets, steel strip in coil, flats and sections 5 or under in thickness | No. 5 | 19 min. | 180° | 2.0 times the thickness | No. 1 |
| | | | | | | Steel plates and sheets, steel strip in coil, flats and sections over 5 up to and incl. 16 in. thickness | No. 1A | 15 min. | | | |
| | | | | | | Steel plates and sheets, steel strip in coil, flats and sections over 16 up to and incl. 50 in thickness | No. 1A | 19 min. | | | |
| | | | | | | Steel plates and sheets, flats and sections over 40 in thickness | No. 4 | 21 min. | | | |
| | | | | | | Steel bars 25 or under in diameter, side or distance across flats | No. 2 | 18 min. | 180° | 2.0 times the diameter, side or distance across flats | No. 2 |
| | | | | | | Steel bars over 25 in diameter, side or distance across flats | No. 14A | 20 min. | | | |

Table 3. (concluded)

| Symbol of grade | Yield point or yield strength N/mm ² | | | | Tensile strength N/mm ² | Thickness of steel product ⁽¹⁾ mm | Test piece | Elongation % | Bendability | | |
|-----------------|--|----------------------------|-----------------------------|----------|---|--|------------|---------------------|------------------|---|------------|
| | Thickness of steel product ⁽¹⁾ mm | | | | | | | | Angle of bending | Inside radius | Test piece |
| | 16 or under | Over 16 up to and incl. 40 | Over 40 up to and incl. 100 | Over 100 | | | | | | | |
| SS540 | 400 min. | 390 min. | — | — | 540 min. | Steel plates and sheets, steel strip in coil, flats and sections 5 or under in thickness | No. 5 | 16 min. | 180° | 2.0 times the thickness | No. 1 |
| | | | | | | Steel plates and sheets, steel strip in coil, flats and sections over 5 up to and incl. 16 in thickness | No. 1A | 13 min. | | | |
| | | | | | | Steel plates and sheets, steel strip in coil, flats and sections over 16 up to and incl. 50 in thickness | No. 1A | 17 min. | | | |
| | | | | | | Steel bars 25 or under in diameter, side or distance across flats | No. 2 | 13 min. | 180° | 2.0 times the diameter, side or distance across flats | No. 2 |
| | | | | | | Steel bars over 25 in diameter, side or distance across flats | No. 14A | 16 min. | | | |

Note (1) As to the term "thickness of steel product" for sections, it means the thickness at the position of which the test piece(s) is taken as shown in annex 1 figure 1.

With this respect, in the case of bars, it means the diameter for round bars, the side length (or width) for square bars and distance across flats for hexagonal bars.

Remarks 1 For the elongation of No. 4 test piece for steel plates over 90 mm in thickness, it shall be subtracted 1 % from the values of elongation given in table 3 per each increase of 25.0 mm or its fraction in thickness. However, the limit to be subtracted shall be 3 %.

2 No. 3 test piece may be used for the bend test for the steel product 5 mm or under in thickness.

6 Shape, dimensions, mass and tolerances thereof The shape, dimensions, mass and tolerances thereof shall be in accordance with the following standards.

JIS G 3191, JIS G 3192, JIS G 3193, JIS G 3194

With this respect, the width tolerances for the cut-edged steel plate, sheet and steel strip in coil, and length tolerances for the steel plate and sheet shall be in accordance with class A tolerances given in **JIS G 3193**, unless otherwise specified. Tolerances of plate thickness not specified in **JIS G 3193** may be agreed between the purchaser and the supplier.

7 Appearance Appearance of the steel product shall be in accordance with clause 9 in **JIS G 3191**, clause 9 in **JIS G 3192**, clause 6 in **JIS G 3193** and clause 10 in **JIS G 3194**.

8 Test

8.1 Chemical analysis

8.1.1 General requirement for chemical analysis and sampling method of specimen for analysis The chemical composition of the steel product shall be determined by cast analysis, and the general requirements for chemical analysis and sampling methods of specimen for analysis shall be as specified in clause 8 of **JIS G 0404**.

8.1.2 Analytical method The method for chemical analysis shall be in accordance with any one of the following standards:

JIS G 1211, JIS G 1213, JIS G 1214, JIS G 1215, JIS G 1253, JIS G 1256, JIS G 1257, JIS G 1258

8.2 Mechanical test

8.2.1 Test in general General requirements for mechanical testing shall be as specified in clause 9 of **JIS G 0404**. With this respect the sampling method of specimen shall conform to class A, and the number of test pieces and the sampling position shall be as follows.

The bend test may be omitted unless otherwise specified by the purchaser.

8.2.2 Number of test pieces for tensile test and bend test The number of test pieces for tensile test and bend test shall be as follows:

- a) **Steel plate and flat** A test lot shall consist of the steel product from one heat where the maximum thickness of the steel product is within twice the minimum thickness, and respective one test piece shall be taken therefrom. When the mass of one test lot exceeds 50 t, however, respective two test pieces shall be taken. With this respect, if mass of a single steel plate exceeds 50 t, respective one test piece shall be taken from the said plate.
- b) **Steel coil and cut-to-length therefrom** A test lot shall consist of the steel product from one heat rolled to the same thickness, and respective one test piece shall be taken therefrom. When the mass of one test lot exceeds 50 t, however, respective two test pieces shall be taken.

- c) **Steel section** A test lot shall consist of the section from one heat rolled to the same sectional profile group where the maximum thickness of the section is within twice the minimum thickness, and respective one test piece shall be taken therefrom. When the mass of one test lot exceeds 50 t, however, respective two test pieces shall be taken.
- d) **Steel bar** A test lot shall consist of the steel bar from one heat rolled to the same sectional profile group where the maximum diameter (side length or distance across flats) is within twice the minimum diameter (side length or distance across flats), and respective one test piece shall be taken therefrom. When the mass of one test lot exceeds 50 t, however, respective two test pieces shall be taken.
- e) **Number of test pieces for heat-treated steel product** The number of test pieces for the heat-treated steel product composed of the same heat rolled to the same sectional profile group subjected to heat treatment under the same heat treatment conditions shall be determined in accordance with a), b), c), and d) in this item, respectively.

8.2.3 Sampling position of the test piece for tensile tests and bend test Sampling position of the test piece for tensile tests and bend tests shall be as specified in **JIS G 0416**. However, annex 1 may be applied.

Test pieces of steel coil shall be sampled from the position adjacent to the part of the material to be evaluated.

8.2.4 Test piece The tensile test piece and the bend test piece shall be as follows:

- a) No. 1A, 2, 4, 5 or 14A test piece specified in **JIS Z 2201**.
- b) No. 1, 2 or 3 test piece specified in **JIS Z 2204**.

8.2.5 Test method The methods for tensile test and bend test shall be as follows:

- a) **JIS Z 2241**
- b) **JIS Z 2248**

8.2.6 Tensile test in the case where tensile test piece having specified dimensions can not be taken In the case where it is infeasible to secure the specified dimensions of the test piece, matters on execution of tensile testing, test result values or the like shall be agreed upon between the purchaser and supplier.

8.2.7 Omission of tensile test of steel coil The tensile test of the steel coil may be omitted when approved by the purchaser.

9 Inspection

9.1 Inspection The inspection shall be carried out as follows:

- a) General requirements for inspection shall be as specified in **JIS G 0404**.
- b) The chemical composition shall conform to the requirements specified in clause 4.

- c) The mechanical properties shall conform to the requirements specified in clause 5.
- d) The shape, dimensions and mass shall conform to the requirements specified in clause 6.
- e) The appearance shall conform to the requirements specified in clause 7.

9.2 Reinspection The steel product which has not passed the tensile test and bend test may be subjected to a retest according to the specification of 9.8 in JIS G 0404 to determine whether it is acceptable or not.

10 Marking The steel product which has passed the inspection shall be marked on each piece or each bundle with the following details by suitable means. However, a part of them may be omitted subjected to the agreement between the purchaser and supplier.

- a) Symbol of grade
- b) Heat number or inspection number
- c) Dimensions
- d) Quantity or mass of each bundle (for steel plate, sheet and steel strip in coil)
- e) Manufacturer's name or its identifying brand

11 Report The report shall conform to the specification of clause 13 in JIS G 0404. When required, the manufacturer shall submit the symbol 2.3 or 3.1.B of table 1 of JIS G 0415 to the purchaser.

In the case where the remarks of table 2 is applied, the content of added element(s) shall be additively described in the test report.

Attached Table 1 Normative references

- JIS G 0404 *Steel and steel products—General technical delivery requirements*
- JIS G 0415 *Steel and steel products—Inspection documents*
- JIS G 0416 *Steel and steel products—Location and preparation of samples and test pieces for mechanical testing*
- JIS G 1211 *Iron and steel—Methods for determination of carbon content*
- JIS G 1213 *Iron and steel—Methods for determination of manganese content*
- JIS G 1214 *Iron and steel—Methods for determination of phosphorus content*
- JIS G 1215 *Iron and steel—Methods for determination of sulfur content*
- JIS G 1253 *Iron and steel—Method for spark discharge atomic emission spectrometric analysis*
- JIS G 1256 *Iron and steel—Method for X-ray fluorescence spectrometric analysis*
- JIS G 1257 *Iron and steel—Methods for atomic absorption spectrometric analysis*
- JIS G 1258 *Iron and steel—Methods for inductively coupled plasma atomic emission spectrometry*
- JIS G 3191 *Dimensions, mass and permissible variations of hot rolled steel bars and bar in coil*
- JIS G 3192 *Dimensions, mass and permissible variations of hot rolled steel sections*
- JIS G 3193 *Dimensions, mass and permissible variations of hot rolled steel plates, sheets and strip*
- JIS G 3194 *Dimensions, mass and permissible variations of hot rolled flat steel*
- JIS Z 2201 *Test pieces for tensile test for metallic materials*
- JIS Z 2204 *Bend test pieces for metallic materials*
- JIS Z 2241 *Method of tensile test for metallic materials*
- JIS Z 2248 *Method of bend test for metallic materials*

Annex 1 (normative)

Sampling position of the test piece

1 Scope This annex specifies the sampling position of the test piece for tensile tests and bend tests.

2 Applicable date This annex applies until Dec. 31, 2008.

3 Sampling position of the test piece for tensile tests and bend tests Sampling position of the test piece for tensile tests and bend tests shall be as follows.

- a) **Steel plate, sheet and flat** The centre of the test piece shall be at a quarter-width position from a side edge, and further in the case of No. 4 test piece, it shall be at a quarter-thickness position from a surface as well as a quarter-width position from a side edge. When it is infeasible to allow the centre of the test piece to be at a quarter-width position from a side edge or at a quarter-thickness position from a surface, however, the sampling should be performed as close to the aforementioned position as possible.
- b) **Steel section** The sampling position shall be as shown in annex 1 figure 1. When it is infeasible to take a specimen as shown in annex 1 figure 1, the sampling position should be as close to the aforementioned position as possible. In the case of the steel section from which a specimen is unable to take in the same manner as shown in annex 1 figure 1, the sampling position for the I section should be applied *mutatis mutandis*. For other steel sections, it should be agreed between the purchaser and the supplier.

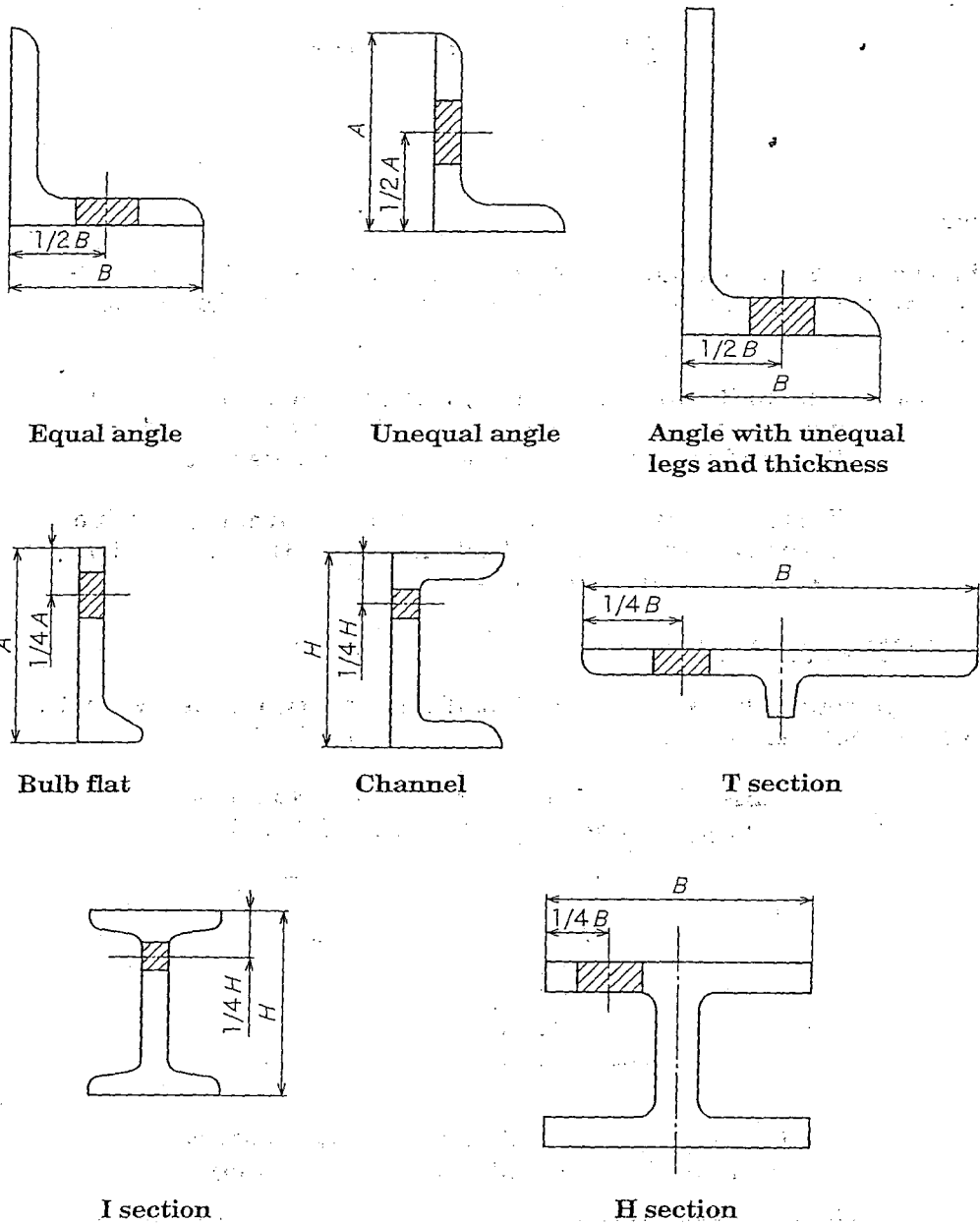

Annex 1 Figure 1 Sampling position of the test piece for tensile tests and bend tests for steel section